

Neptune Meet Runner Guide

Updated January 12, 2017

The responsibility of the running team – head runner, results gatherer and poster – is to prepare paperwork for distribution and distributing and collecting paperwork in a timely manner to minimize delay of the meet.

1. Head runner stamps 3 sets of lane assignments. Top of paper says “Meet program”
 - a) “Announcer”
 - b) “Colorado”
 - c) “Referee”

Give to runner to deliver to appropriate person

2. When there is a **25 yard event**, an extra “Referee” paper needs to be stamped and given to referee.
3. On check-in sheets, write the number of the event in the upper right hand corner. Use **pink** marker for girls’ events and **blue** marker for boys’ events. Also stamp “Post”. Have runner use blue painters tape to tape to inside of window and outside of window behind starting blocks. Hang in numerical order. Use one area for boys and one area for girls’ sheets.
4. Timers’ sheets are to be delivered to the appropriate timer, based on lane number. After each event, the runner will collect the timing sheets and put them in the proper order (1-8) and deliver to Colorado.
5. Runner also collects clothes-pinned packet from Admin person, if the clothes pin is placed on the top edge of the packet. If the clothes pin is on the side edge, it has not been verified yet. Admin will also initial the top right hand corner of the packet. Runner delivers the packet to the computer person.
6. Stamp “Post” on results sheets and write the number of the event in the upper right hand corner. Use **pink** marker for girls’ events and **blue** marker for boys’ events. Runner uses blue painters tape to tape to inside of window at the shallow end of pool. Hang in numerical order and use one area for girls’ events and one area for boys’ events.
7. Stamp “Awards” on other results sheets and wait for labels to be matched with the event. Labels are only made for 12 and under events, since ribbons are only awarded to 12 and under events. Give “Awards” sheets to the awards person for filing.
8. When computer person hands head runner a clothes-pinned packet, the runner then takes it back to the Admin person.
9. Periodically, the runner should take down old lane assignment sheets to prevent a lot of clutter on the window. The old sheets can be placed in the recycle bin.
10. Head runner also needs to train replacement head runner and new runners as need arises.

Runner

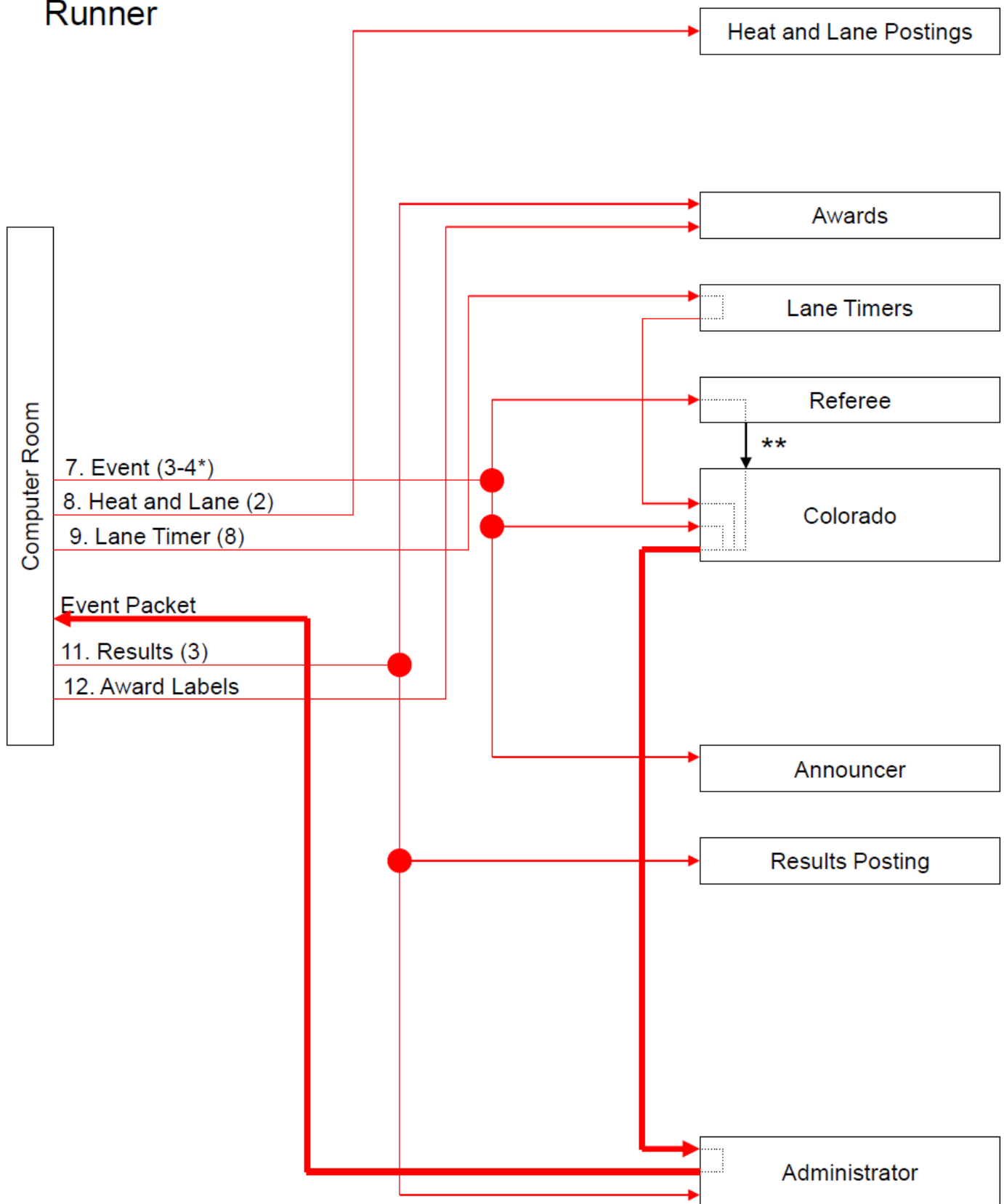

* 4 copies of Events for 25 yard events, 2 for referees, one on each side of pool; else 3 copies.

** Referee gives their event sheets directly to Colorado operator to compile event packet.