

## Contents

Musts .....	2
Wants .....	2
Architecture .....	2
High Level System Diagram.....	4
Component Options to Buy .....	5
PV Panels.....	5
Roof Clamps .....	5
Power Electronics.....	5
Option 1: Integrated Power Centers that include DC Charge Controller, Inverter/Charger and AC Power Manager.....	5
Option 2: separate DC Charge controller and interver/charger/AC power manager: .....	5
System Options .....	7
Least expensive .....	7
American Separate Components – currently leading choice.....	7
American Integrated .....	8
Most Expensive, but Best Warranty .....	8

## Musts

1. Minimize grid energy use for environmental and energy independence reasons.
2. Obtain at least a neutral return on investment during warranty period.
3. Purchase safe, UL Listed and certified parts.
4. Provide enough Photovoltaic (PV) power and storage to not need to use the grid during peak solar production, with the ability to add more PVs, batteries and inverters over time to extend the time we don't need the grid as battery prices and longevity improve, preparing for eventual removal of natural gas that currently runs our furnace and hot water heater; hot water will be preheated with solar. Installation in Santa Rosa, California.
5. Provide enough backup power and storage during weeklong power outages during fire season to run the refrigerator, crock pot or air fryer, network, cell phones, laptops, a small server, and restricted use of front-loading washing machine; will use indoor and outdoor clothes lines for drying,
6. Automatic switchover when grid goes down so fridge keeps food cold so it does not spoil. Switchover can interrupt power for up to 2 hour off period to achieve this.
7. Oversize components and minimize their number for reliability.
8. PVs must have at least a 10 year workmanship and a 25 year performance warranty. All other components must have at least a 5 year warranty and be locally repairable.
9. System must support a custom made battery with Battery Management System (BMS) and respond to its shutdown command in a fail-safe manner in the event of overcharging or overdischarging one more more working or broken cells. To achieve this, documentation, technical support and warranty must cover this.
10. System must be easily self-installable, monitorable, troubleshootable and repairable with minimal down time waiting for parts, with local professionals that can help if needed.

## Wants

11. No interruption during power outage so server can stay up unattended. If this is not possible then an Uninterruptable Power Supply can be added for the server and network.
12. Web-based remote monitoring and control via WiFi.
13. Purchase equipment made in America when competitive.

## Architecture

Reuse 12 2003 Sharp 180W PV panels from 1.8 kW system, assuming they test out well – power production is down 50% and don't know what it is yet. Retire 2500W SMA Sunny Boy grid tied inverter. This system offset around 80% of our usage when it was new and before getting electric vehicles.

Purchase enough PV panels and a high enough power inverter to double our power generation to at least 3.6 kW to offset the rest of our house use and our electric vehicle use.

For the batteries:

- First reuse 32 100 Ah LiFePO4 cells left over from an abandoned electric vehicle conversion project from 2009 with a home made Arduino-based battery management system to provide a 48V 200 Ah 9.6 kWh battery bank.
- Then reuse 8 out of 12 100 Ah 4 cell Valence LiFePO4 modules in current use in an electric vehicle since 2008.
- Eventually replace with more sustainable batteries that last longer and are made from more common materials, such as refurbished Edison nickel iron batteries from the 1970s when they stopped being made, or as old as when they were first introduced in early as the early 1900s, or replicas that don't use any lithium if they can be purchased, or custom made if an original can be found that can be copied or if plans can be found or manuals have enough information.

Battery powered 48VDC to 120V/240V split phase single inverter/charger tied to grid, complete home circuit breaker box, and batteries. In parallel have one or more parallel 48V output charge controllers.

60 cells per PV panel, 5.5' long instead of 6.5' long, smaller for easier large array roof installation.

S-5! S-5-S clamp-on roof panel mounts to attach to our standing seam metal roof.

# High Level System Diagram

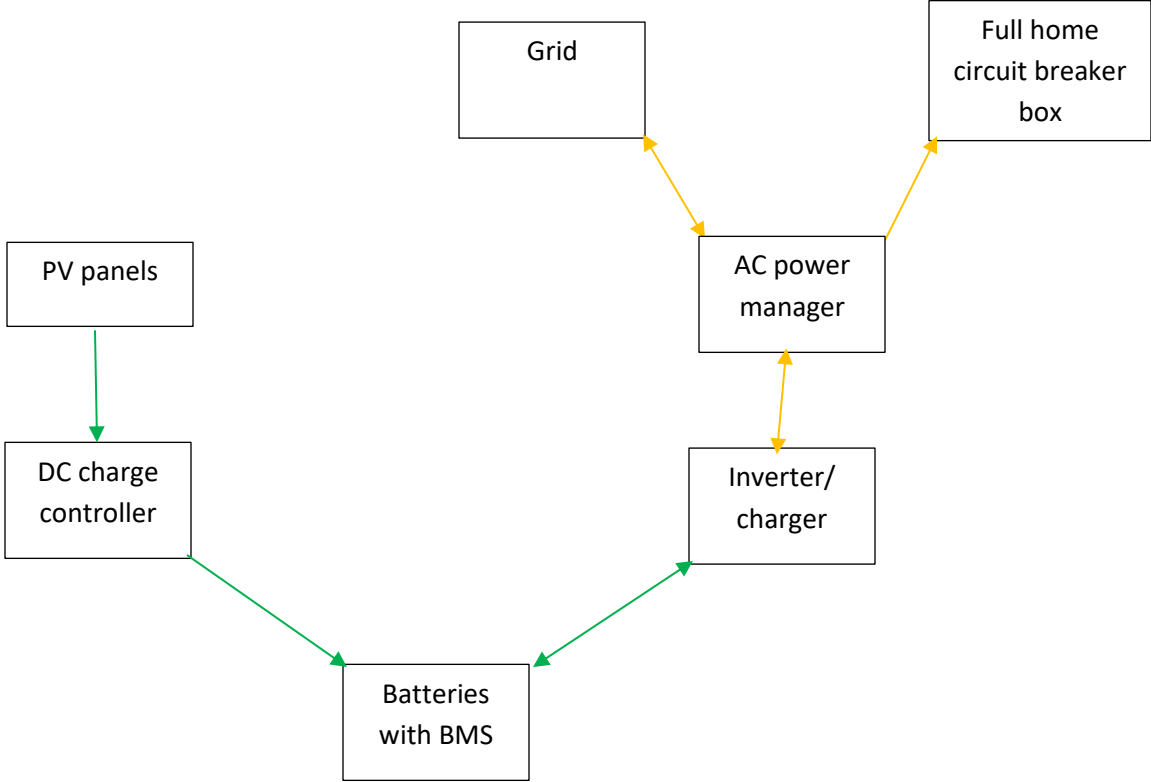

## Component Options to Buy

From Wholesale Solar, [www.wholesalesolar.com](http://www.wholesalesolar.com)

### PV Panels

Heliene 320 Black Mono, 7 at \$256 each = \$1,792, 40V open circuit, 9.4 amp max, Canada

Mission Solar 310 Black Mono PERC, 7 at \$259 each = \$1,813, +\$21, 40.1V open circuit, 9.8 amps max, Texas

LG NeON2 LG-335N1K-V5 Black/Black Mono, 7 at \$380 each = \$2,660, +\$868 but workmanship warranty is 25 years instead of 10, 38.6V open circuit, 8.3 amps max, South Korea

### Roof Clamps

S-5! S-5 U standing seam metal roof clamps, 28 x \$13 = \$364, USA

### Power Electronics

Option 1: Integrated Power Centers that include DC Charge Controller, Inverter/Charger and AC Power Manager

Outback Power FPR-40408A-01 Flexpower Radian Power Center, \$6,250, Arizona

Option 2: separate DC Charge controller and interver/charger/AC power manager:

#### *DC Charge Controllers*

Outback Power Flexmax FM80, \$515 for 80 amp 150V open circuit PV array, Arizona

Schneider Conext XW 60-150 MPPT, \$579 for 60 amp 150V open circuit PV array, France

Morningstar TriStart TS-MPPT-60, \$599 for 60 amp 150V open circuit PV strings, Pennsylvania

Magnum Energy PT-100, \$925 for 100 amp 240V open circuit PV strings, Washington and Minnesota

Victron Energy SmartSolar MPPT 250/100-Tr, \$932 for 100 amp 250V open circuit PV array, The Netherlands

### *Inverter/Chargers and AC Power Managers*

Schnieder Electric Conext SW 4048 NA, \$1,595, France

Magnum Energy MS4448PAE, \$1,995, +\$400, Washington and Minnesota

SMA Sunny Island 6048-US-10, \$9,990 (2 x \$4,995), +\$8,395 but 10 year warranty instead of 5, Germany

## System Options

Are array strings mix and matchable or are they hard wired together and need to be matched or have separate charge controllers? This will change the numbers below but apparently not dramatically.

Need to add other parts such as cutoff switches, wire and cables, custom BMS and battery rack mount materials,

### Least expensive

7 Heliene \$320W panels, \$1,792

28 S-5! S-5 U standing seam metal roof clamps, \$364

Ouback Power Flexmax DC Charge Controller, \$515

Schnieder Electric Conext SW 4048 NA, \$1,595

\$4,266 total

### American Separate Components – currently leading choice

7 Mission Solar 310W panels, \$1,813

28 S-5! S-5 U standing seam metal roof clamps, \$364

Morningstar TriStart TS-MPPT-60 Charge Controller, \$599

Magnum Energy MS4448PAE Inverter/Charger, \$1,995

\$4,771 total, +\$505

## American Integrated

7 Mission Solar 310W panels, \$1,813

28 S-5! S-5 U standing seam metal roof clamps, \$364

Outback Power Radian Power Center, \$6,250

\$8,427 total, +\$4,161; why is this so expensive – are there a lot of parts to add to the separate component systems above?

## Most Expensive, but Best Warranty

7 LG NeON2 LG-335N1K-V5 panels, \$2,660

28 S-5! S-5 U standing seam metal roof clamps, \$364

Victron Energy SmartSolar MPPT 250/100-Tr Charge Controller, \$932

2 SMA Sunny Island 6048-US-10s, \$9,990

\$13,946, +\$9,680